

## **OUTOTEC DIRECT LEACHING APPLICATION IN CHINA**

T. Haakana, B. Saxén, L. Lehtinen, H. Takala  
Outotec Research Oy, Kuparitie 10, PO Box 69 FI-28101 Pori, Finland

M. Lahtinen, K. Svens, M. Ruonala  
Outotec Oyj, Base Metals, Riihitontuntie 7 C, PO Box 86  
FI-02200 Espoo, Finland

Xiao Gongming  
Dept. of Sci&Tech Dev, Zhuzhou Smelter Group Co., Ltd.,  
Qingshuitang, Zhuzhou 412004, Hunan, P.R. China

### **Abstract**

Outotec's direct leaching process is an atmospheric leaching process for sulphidic zinc concentrates. The direct leaching process, based on special leaching reactors developed by Outokumpu, is the most economical way to produce electrolytic zinc. The production scale applications of the process realized so far are in use at Boliden's Kokkola and Odda zinc plants.

A new full-scale application of Outotec's direct leaching process will be started in 2008 in China. The process is integrated to the existing production plant, replacing part of the old production facilities by modern technology. Besides high zinc extraction the plant expansion and modernization offers also indium recovery, iron precipitation and solution purification processes. The process equipment includes tailor-made reactors designed on the basis of the work and experience of Outotec research center.

Keywords: zinc, concentrate, atmospheric leaching, technology, indium, iron precipitation, solution purification, Outotec

## **1. Introduction**

In April 2007 Outokumpu Technology's name was changed to Outotec. The choice of name Outotec represents the company's evolution from a technology division within Outokumpu, through expansion and several acquisitions, to an independent listed company with its own brand values and identity. Outokumpu Technology was famous for its innovative and environmentally sound proprietary technologies, many of which had become industry benchmarks. Outotec is the name that has a strong link to the company's past and the expertise the customers have learned to trust.

Outotec, former Outokumpu Technology, developed atmospheric direct leaching technology of zinc concentrates in the middle of 1990's [1,2]. This technology has been practiced in industrial scale since 1998 in Kokkola, Finland [3] and since 2004 in Odda, Norway [4]. Originally the technology was developed for company's internal use only, but due to the rearrangement of the company's business goals Outotec atmospheric direct leaching technology is now a commercially available product, which offers a way to produce zinc without generating sulphur dioxide that is formed in the conventional roasting-leaching-electrowinning route.

First communications and discussions between the Chinese company Zhuzhou Smelter Group (Zhuzhou) and Outotec, related to the current expansion project, was held during the first years after the millennium change. At that time Zhuzhou informed that they have plans to expand the annual zinc smelter production by 100 000 tonnes of Zn ingots and the utilization of a concentrate direct leach procedure was considered for the expansion in the leaching area.

After the first preliminary cost estimates and process evaluations, a batch test series on concentrates based on the Outotec's counter-current direct leach process was performed by Outotec during the second half of 2005. Indium recovery was considered already at that time. Based on the good results gained on the batch test series, Outotec performed direct leach bench-scale pilot tests on zinc concentrates and neutral leach residue received from Zhuzhou during the first half of 2006. The tests provided good results as described later in this paper. Both test phases mentioned above were accompanied by economical feasibility studies.

Based on the good results of the tests and the economical evaluation from both sides, Zhuzhou signed agreements with Outotec in December 2006 to implement the Outotec atmospheric zinc concentrate direct leaching technology together with the arsenic based Outotec solution purification technology, which includes the special feature of removing chloride from the solution derived from the chloride in the concentrates.

## **2. Zhuzhou Zinc Production**

The history of the Zhuzhou smelter started with the construction of a lead smelter, which was commissioned in 1960. The lead smelter is based on a sinter/blast furnace

technology together with an electrolytic refinery having an annual capacity of 90 000 tonnes.

After having a part of the state organization, Zhuzhou Smelter Group Co. Ltd. became in 2004 a part of the Hunan Nonferrous Metals Holding Group Co. Ltd. (HNMC). Presently HNMC is the controlling shareholder of Zhuzhou.

The first zinc plant line using roasting-leaching-electrowinning process was commissioned in 1968 with an annual capacity of 100 000 tonnes using neutral leaching together with Waelz kiln treatment of the leach residue. Major portion of the concentrates are supplied from mines in Hunan, Guangdong and Guangxi provinces, as some is imported. After several de-bottlenecking actions the zinc smelter reached the annual zinc production capacity of 150 000 tonnes in the early 1990s.

After the major expansion done in 1996 a second roast-leach-electrowin plant brought up the total zinc slab production capacity of the Zhuzhou zinc operations to 250 000 tonnes in 1997. Integration of Outotec atmospheric direct leaching process to the existing production facilities will result in a nominal zinc cathode production capacity of 350 000 tonnes based on concentrates in 2008.

The SO<sub>2</sub> gas from the old four roasters is sold to a chemical company, but the new roaster based on Outokumpu/Lurgi technology, nowadays Outotec, has its own 180 000 tonnes/a sulphuric acid plant, into which the Boliden-Norzink, nowadays Outotec, mercury removal [5] was introduced at the millennium change.

The leaching stage of calcine consists of neutral and weak acid (about 80<sup>0</sup>C) leaching steps. Leach residue, which contains zinc mainly as zinc ferrites and other valuable metals, is treated in five Waelz furnaces. Waelz oxide is treated in multi-hearth furnaces in order to remove halogens before oxide leaching. The soluble zinc is returned to neutral leaching step and indium is recovered by solvent extraction and electrolysis. The annual indium production capacity is larger than 30 tonnes after several enlargement operations.

In the solution purification area both copper and cadmium are removed by means of zinc dust. Cadmium is melted and recovered as crude cadmium by distillation. The cadmium cathode is melted and cast. Copper cake is transported to the copper smelter. Cobalt is removed with two different methods, namely with sodium ethyl xanthate and copper sulphate at low temperature in the old plant line and with zinc dust and Sb<sub>2</sub>O<sub>3</sub> in new plant line.

The electrowinning consists of two tank-houses, both equipped with 1.1 m<sup>2</sup> cathodes. The cathodes in both the tank-houses are stripped manually. In the casting area the cathodes are melted in induction furnaces. The molten zinc is cast in the form of 22 kg slabs and 1.2 tonne jumbos. Zinc qualities produced are SHG, HG and alloys.

### **3. Capacity increase by Direct Leaching**

The production capacity increase of the existing zinc plant by utilizing Outotec's atmospheric direct leaching process of zinc concentrates offers several advantages that are described by Lahtinen et al. [6]. Lahtinen et al. [6] also compared the atmospheric process to pressurized direct leaching and summarized the environmental benefits that the direct leaching process can give. Environmental issues played an important role, when Outotec's direct leaching technology was chosen to Zhuzhou. Modern technology enables to reduce SO<sub>2</sub> emissions by processing leach residue by atmospheric counter-current direct leaching technology. In addition, Outotec's technology enables the utilization of goethite precipitation process, which reduces the amount of iron residue and also makes the recycle of the iron residue possible.

As explained above, the Zhuzhou zinc process is now based on neutral leaching process of calcine and Waelz treatment of the neutral leaching residue. Now, the expansion will be based on the direct leaching of zinc concentrate and acid leaching of the neutral leaching residue. Both of these factors will increase iron concentration in the product solution of the leaching process. Thus, it was evident that iron removal process is also needed as a part of the expansion.

The choice for iron removal technology was made between jarosite and goethite precipitation processes. Because Zhuzhou zinc smelter is surrounded by settled area and there is no possibility for waste storage pond construction, goethite precipitation was finally chosen. In addition, the goethite precipitate can be further treated in a pyrometallurgical process, like some zinc producers are already doing, enabling the recycling of the material.

Today, when metal prices are high, it is important that all the possible metals are recovered. Lead is a good example, which has reached a very high price level. Typically, in the direct leaching process, lead remains in the leach residue. However, a lead concentrate suitable for lead production can be produced from the leach residue by separating the elemental sulphur and remained sulphide minerals from the Pb-rich fraction. The separation of lead residue and elemental sulphur can be easily done by a flotation process, which will be supplied to Zhuzhou by Outotec.

One interesting feature in the Zhuzhou expansion project was the high indium content of the raw materials. Thus, a method was needed to recover the indium. Based on the Outotec's earlier know-how in this area and the additional development work, Outotec developed a process to precipitate indium selectively from the leaching process solution before the iron precipitation.

After the direct leaching, indium recovery and iron precipitation processes the process solution has to be treated in the solution purification process before the cellhouse. In the direct leaching process chloride, which is removed normally in the roasting process of zinc concentrate, is leached also from the concentrate. This increases the chloride level in the process solution, which causes corrosion problems in the process equipment. Thus, chloride has to be removed. Outotec has developed a chloride removal process,

which is in use at Boliden's Kokkola and Odda zinc smelters. It was a natural choice also for Zhuzhou Smelter.

The Outotec solution purification technology can be based either on arsenic technology or antimony technology. The chloride removal process can be used in both of these processes as it is connected to copper removal step of the solution purification process. A part of the copper removal precipitate is used as a reagent in the chloride removal. The arsenic removal process was chosen for Zhuzhou, because it enables significantly lower zinc dust consumption and also it has proven to be very reliable and safe process at Kokkola zinc plant.

A schematic drawing of the Outotec's counter-current direct leaching of zinc concentrates [7], indium recovery and iron precipitation processes together with the connections to the existing production facilities is presented in Figure 1. Solution from the existing neutral leaching is fed to the new solution purification area delivered by Outotec.

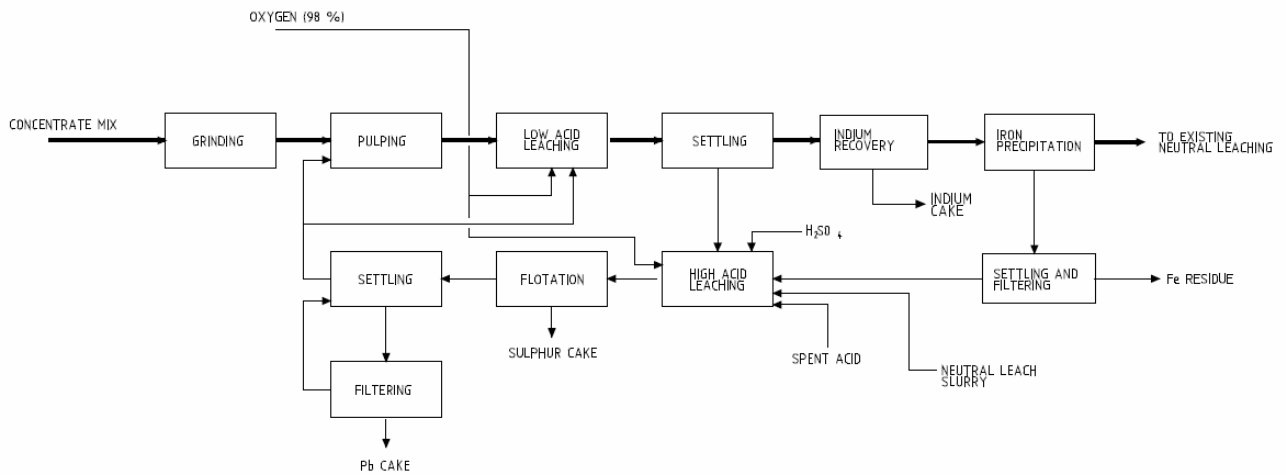

Figure 1. A block diagram of the process implemented for the capacity increase including direct leaching, indium recovery and iron precipitation steps.

#### 4. Research and Technology Development in Outotec

Besides the innovative and environmentally sound proprietary technologies, extensive research and development resources are Outotec's key strengths. Outotec have two in-house research centres, located in Pori, Finland and in Frankfurt, Germany. Extensive RTD facilities enable to develop new technological solutions as well as to apply the existing technologies to new customer industries. Outotec's approach to process development is described in this chapter.

##### 4.1 RTD Procedure

Outotec's approach to process development in this expansion project is schematically described in Figure 2. The expansion is mainly based on existing and proven technology,

which has been tailored to meet the client's requirements. The approach is cost effective and provides reliable and detailed information needed in plant design and economical evaluation.

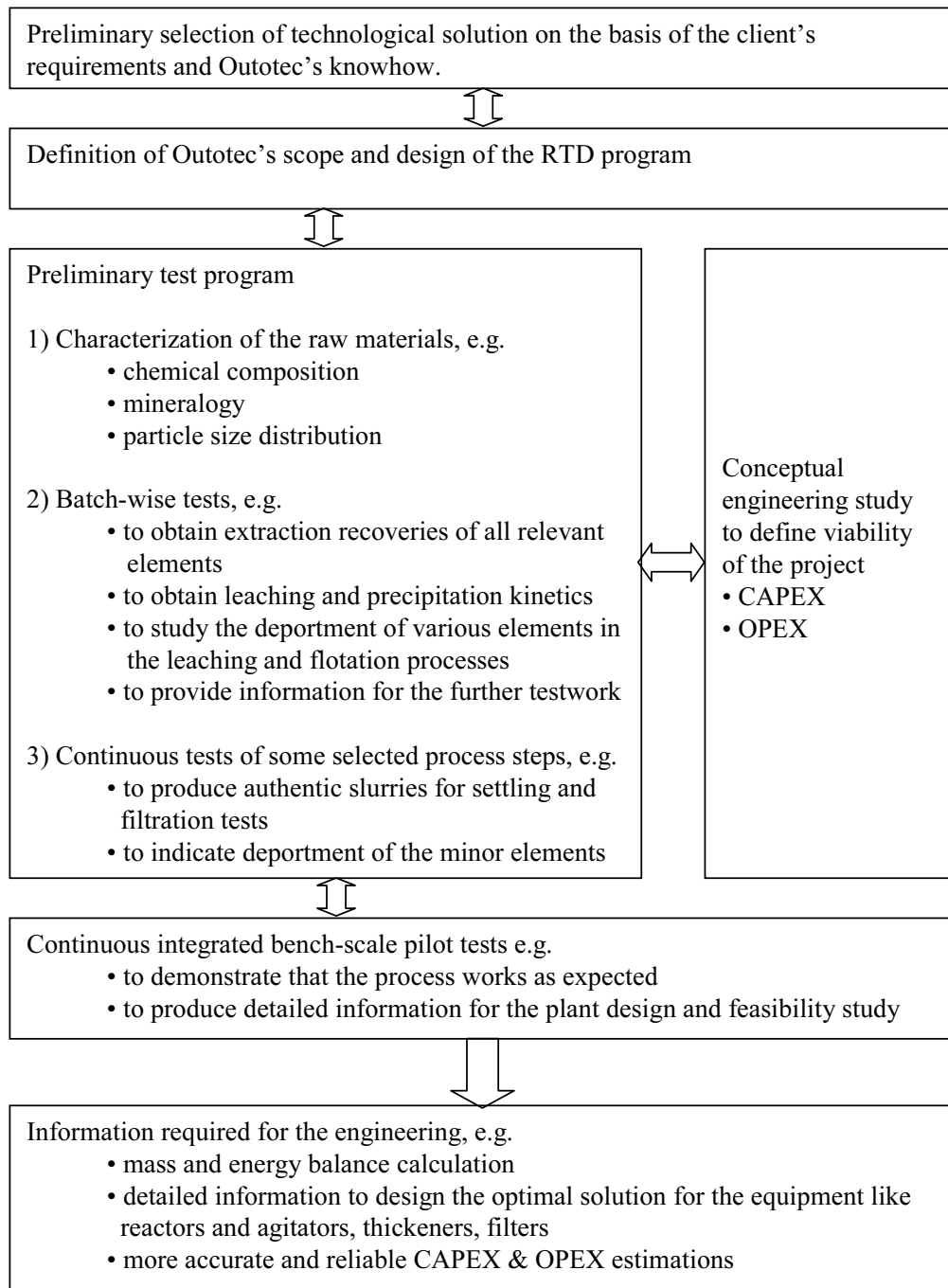

Figure 2. RTD strategy in this project.

#### 4.2 Characterization of raw materials

Testing the leaching properties of several different sulphidic zinc concentrate mixtures and leach residues of the existing neutral and weak acid leaching steps started the test program. Later two concentrate mixtures and leach residues were selected for the more

detailed study. Waelz oxide was chosen as a neutralization agent in precipitation steps. Main components and particle sizes of the tested samples are shown in Table 1.

Table 1. Composition of the raw materials tested.

		Concentrate mixture 1	Concentrate mixture 2	Leach residue 1	Leach residue 2	Waelz oxide
Cu	%	1.0	0.63	1.1	0.85	0.07
Fe	%	10.6	10.7	15.5	22.4	0.59
S	%	32.7	32.6	7.7	4.5	2.2
Zn	%	45.4	45.9	28.4	21.8	63.8
In	ppm	190	125	164	315	840
Particle size after basic pretreatment:						
D50%	um	46	53	35	33	
D90%	um	148	184	86	157	

Tested concentrates had relatively high iron and indium contents but otherwise rather typical composition. Zinc occurred in leach residues mainly as zinc ferrites and zinc sulphates. Small amounts of zinc oxides, zinc silicates and zinc sulphides were also present in the leach residues.

#### 4.3 Preliminary test program

Preliminary test program comprised

- batchwise atmospheric direct leaching of zinc concentrate and flotation of the formed leach residues
- batchwise leaching tests of leach residues
- batchwise and continuous indium precipitation tests
- batchwise iron removal as goethite

Batch-wise leaching tests and flotation tests of the formed leach residues were carried out to define zinc and indium leaching recoveries and to find optimal process conditions for these concentrates, to study the deportment of various elements in the leaching and flotation steps and to characterise the formed residues as well as to produce information for the further testwork.

Due to the high indium content in the zinc concentrates, indium recovery is an important issue in the planned process. Batch-wise indium precipitation tests were carried out to define the role of the most relevant parameter i.e. temperature and pH affecting in the precipitation, the precipitation recovery of indium and the quality of the formed indium precipitate. Besides batchwise precipitation tests a continuous bench-scale pilot test of indium precipitation was carried out.

In the planned process, indium is leached in the direct leaching step and precipitated by neutralizing the solution to pH 3...4 by Waelz oxide. Indium precipitate is treated in the

existing process steps of Zhuzhou, including leaching, solvent extraction and electrowinning, in order to recover indium for a saleable product.

Batch-wise iron precipitation tests were also made in this stage of the project. Purpose of the tests was to determine the effect of the most important parameters on the iron precipitation rate and the quality of the goethite precipitate. Experiments were carried out both with synthetic solution and solution retrieved from direct leaching and indium precipitation. Waelz oxide was used as neutralising reagent.

#### 4.3.1 Atmosphere direct leaching of zinc concentrates and neutral leach residues

Leaching of zinc concentrates is based on the oxidation of zinc sulphide in an acidic environment. The reaction system is of complex nature and not fully understood. Several parallel and consecutive reactions take place simultaneously and also physical phenomena play an important role in the leaching system. However, the direct leaching of sulphide minerals can be written with the following simplified reaction equations. The reduction of ferric iron is accomplished by metal sulphides, which are leached:

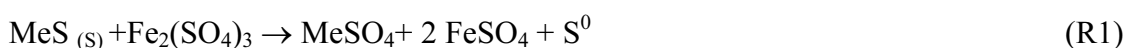

where Me = Zn, Fe, Cu, Co, Ni, Cd, Pb etc. Formed ferrous iron is oxidized by molecular oxygen back to the ferric form:



Reaction rate is often catalysed by copper. The overall reaction can be written as the following simplified equation:

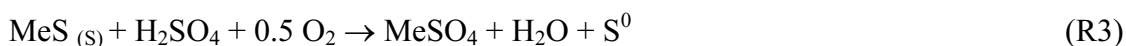

Zinc in the leach residues of neutral and weak acid leaching steps is mainly as zinc ferrites but also small amount of unreacted zinc sulphide is present. Leaching of zinc ferrites can be described written with the following simplified equation:



Leaching of ferrites requires temperature close to 100 °C and acid concentration of above 30 g H<sub>2</sub>SO<sub>4</sub>/l.

The leaching tests with zinc concentrates and leach residues of neutral and weak acid leaching steps were performed in a 10-litre reactor with intensive mixing and oxygen feed at a temperature of 95 °C. Samples were withdrawn with discrete time intervals in order to follow the progress of the leaching. Besides the leaching recoveries of zinc and indium, also the leaching rate of both elements was obtained.

Elemental sulphur was separated from the leach residue in order to produce Pb-rich fraction that is suitable for the existing lead smelter. The department of elements into sulphur concentrate and Pb-rich fraction was evaluated.

Zinc extraction recoveries from both concentrates as well as from both leach residues were 96 – 99 %. Also high indium extraction was obtained.

#### 4.3.2 Indium precipitation

Indium precipitation is carried out by neutralizing the solution to pH 3-4 by means of ZnO of the Waelz oxide. The neutralization of the acid can be written as:



As the solution is neutralised, indium will precipitated as a hydroxide,



Indium may precipitate also as other hydroxide-type compounds.

Minimizing ferric iron content in the solution coming from the direct leaching step minimizes iron precipitation in the indium precipitation step. Iron in ferric form can precipitate as jarosite,

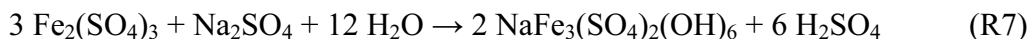

or as hydroxide



Besides batchwise precipitation tests a continuous pilot-run were performed in order to define the settling and filtration properties of the indium precipitate. Indium precipitation results were encouraging. Indium could be removed effectively from the solution and the characteristics of the formed precipitate were good for the further treatment in the existing process steps.

#### 4.3.3 Iron precipitation

The most relevant reactions occurring in the precipitation process are described below. Oxidation of ferrous iron to the ferric iron, which is precipitated as goethite:

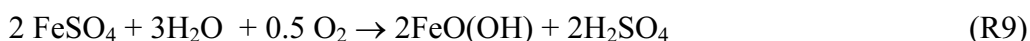

Neutralization of the formed sulphuric acid is made by zinc oxide:



The reaction system can be written as an overall reaction:



Iron precipitation as goethite was studied in laboratory scale reactors of 5-20 litres size. Purpose of the tests was to determine the effect of the most important parameters on the iron precipitation rate. Experiments were carried out both with synthetic solution and also with the solution retrieved from direct leaching and indium precipitation experiments. Waelz oxide was used as a neutralising reagent.

Iron precipitation results were good, resulting in low iron content in the solution. In addition, the characteristics of the formed precipitate were good.

#### 4.4 Continuous testwork

After the results of the preliminary batch tests were evaluated, a continuous bench-scale pilot test run was carried out based on the result of the preliminary batch tests. The parts tested in the continuous run were counter-current leaching of zinc concentrate and leach residue mixtures in two steps (HAL & LAL), indium recovery from the leach solution and iron removal as goethite. A schematic drawing of the pilot set-up is illustrated in Fig 3.

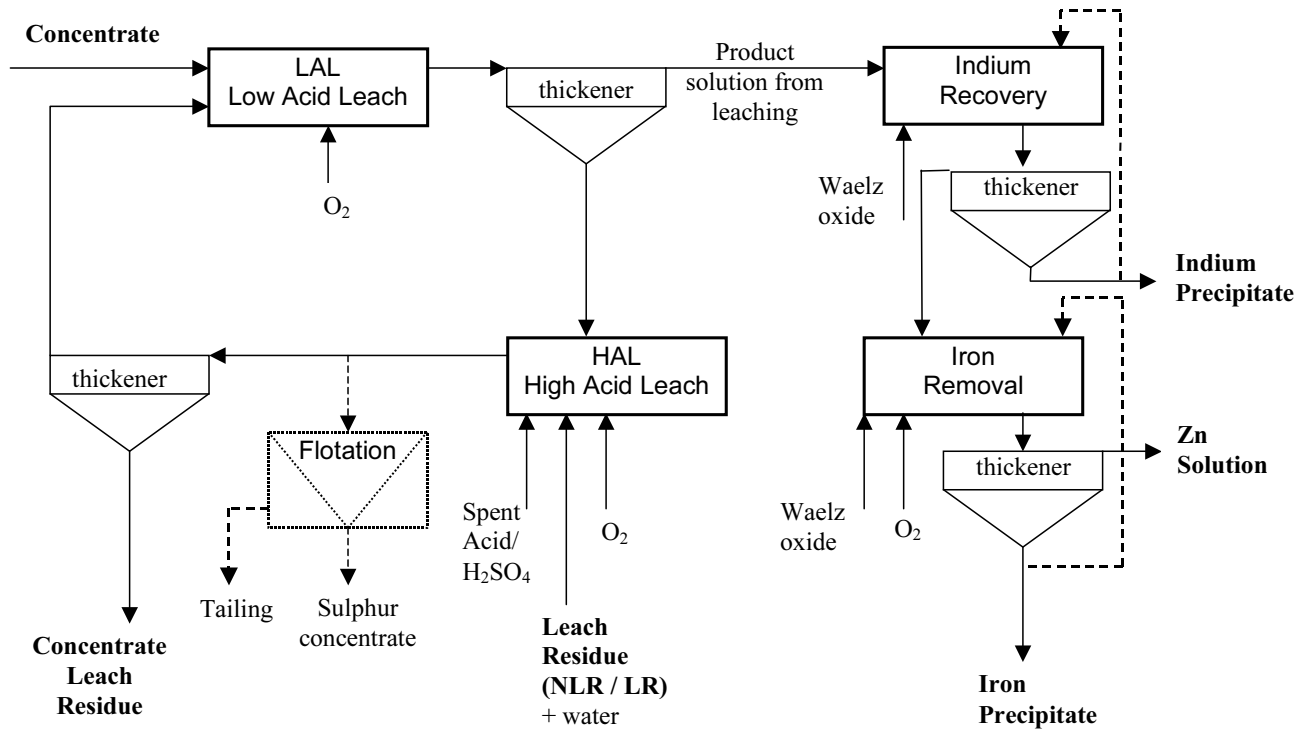

Figure 3. A schematic drawing of the continuous pilot set-up

#### 4.4.1 Leaching section

The tested leaching circuit consisted of a high acid leaching step (HAL) and a low acid leaching step (LAL). By using a counter-current leaching process, a high acidity required for leaching the ferrites of the leach residue (R4) could be obtained simultaneously with a product solution of low acidity. Also, the counter-current process enabled a low ferric ( $\text{Fe}^{3+}$ ) concentration of the product solution, which was needed to minimize iron precipitation in the indium precipitation step.

Both LAL and HAL consisted of successive stirred tank reactors of 10-litre size. The reactors were thermostated to  $95^{\circ}\text{C}$  and gaseous oxygen was fed into the bottom of the reactors. At the end of both lines, a thickener was used for solid-liquid separation. The concentrate was fed to LAL, and the leach residue, together with unleached material from LAL, was fed to HAL. Sulphuric acid was fed to HAL in the form of spent acid, having 176 g/l  $\text{H}_2\text{SO}_4$  and 56 g/l Zn. The product solution from LAL, having around 10 g/l  $\text{H}_2\text{SO}_4$ , was fed to indium recovery.

#### 4.4.2 Indium recovery

Indium precipitation was carried out in two successive stirred reactors of 3-litre size, kept at  $75^{\circ}\text{C}$  temperature. pH was controlled to approx. 3.5 by Waelz oxide feed. The formed indium containing precipitate was filtered and the liquid phase was fed into the iron removal section.

#### 4.4.3 Iron removal

After indium recovery, iron was precipitated in two successive stirred reactors of 5-litre size, kept at 75 °C temperature. Oxygen gas was fed to the bottom of the reactors. pH was kept between 3 and 4 by Waelz oxide feed. The slurry was led to a thickener, and the goethite precipitate was obtained from the thickener underflow. Part of the thickener underflow was circulated to the reactors for seeding purpose.

#### 4.4.4 Flotation tests

Flotation tests with slurry from last HAL reactor were performed batch-wise. In the flotation step, a concentrate (overflow fraction) containing the elemental sulphur and remaining sulphides is separated from the tailings (underflow) fraction containing eg. lead sulphate and silica. The tests were carried out in two stages, a rougher stage and a cleaner stage, using 4 and 1.4 litre test cells with mixing and air feed.

#### 4.4.5 Settling and filtration tests

The settling and filtration properties of the slurries from all piloted stages were evaluated in batch tests during the pilot campaign. In such a test, a 250 ml sample was taken from the reactor; the settling rate was observed at controlled temperature, and the filtration time of the settled phase was measured.

#### 4.4.6 Results

The performance of the main process steps was verified. Some results of the test run are shown in Figure 4 and Table 2.

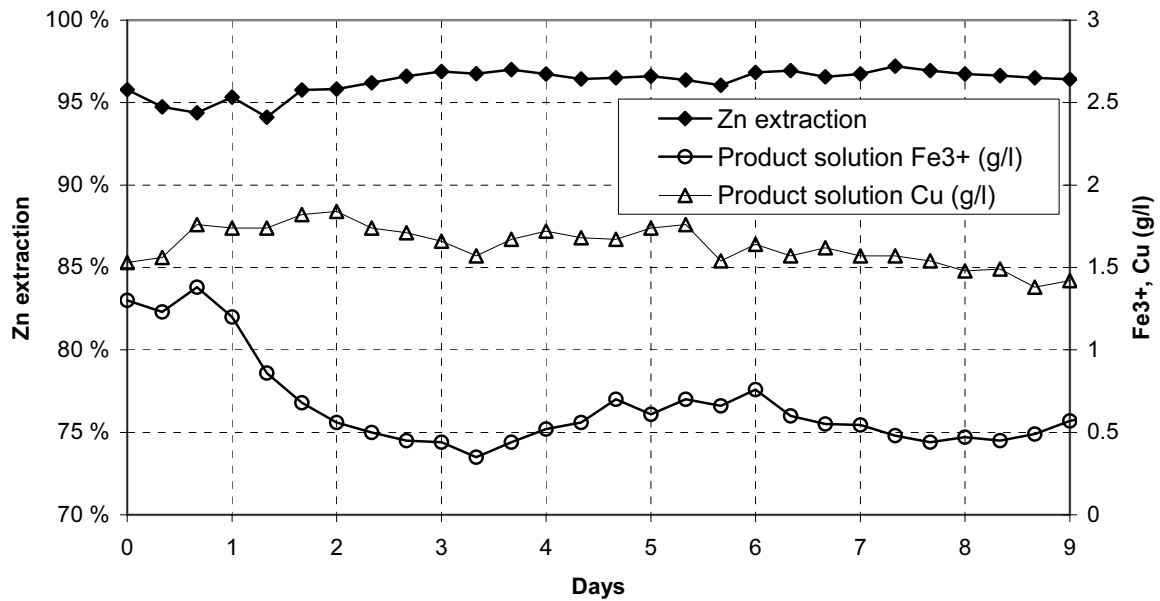

Figure 4. Zn extraction (leaching recovery) as well as Cu and Fe<sup>3+</sup> concentrations of product solution.

Table 2. Average composition of the goethite precipitate.

Element	weigh-%
Fe	38-40
Zn	4-6
Cu	1
Pb	7
S	5

In addition to a verification of the process concept, the test runs produced essential data for process design. Based on the results, mass and energy balance calculations of the process were made with HSC Sim software [8]

### 5. Outotec’s Engineering services

When enough test work has been carried out and the process concept has been proven feasible and economically viable, the next step is normally design and engineering of the plant. Outotec offers tailor-made engineering packages to fit the needs of the customer. The most central part of the equipment, e.g. the leaching reactors [9], must be designed and constructed utilizing all the process know-how that has been gathered during the years of development work. These units are considered as Outotec

proprietary equipment, for which Outotec is in charge of the entire design and construction.

For Zhuzhou, basic engineering was made for both the direct leaching plant, including indium and iron precipitation, and for the solution purification plant. The first step of the basic engineering phase was the process design, where the results from the tests and the preliminary calculations were applied to decide on the detailed flowsheet of the plant and make the mass and energy balances for this. The next steps were the plant design, equipment design, electrical design and automation design. The entire basic engineering phase was carried out during the first half of 2007. In parallel with the basic engineering, the proprietary equipment was designed in detail and purchased.

## **6. Environmental aspects**

Environmental impact of processing methods is of major concern today. One key issue for selecting the Outotec's direct leaching processes is that the production of sulfur dioxide and other harmful gaseous compounds is reduced, especially in comparison to the conventional pyrometallurgical methods. On the other hand, elemental sulphur, which requires special storage area, is formed. Small amounts of compounds like Se, Cd, As, Hg and Pb, hinder further usage of the sulfur residue without purification. Lead rich fraction of leach residue is utilized in the existing lead smelter.

The amount of iron precipitate is dependent on the iron content in the concentrate and also on the iron removal methods. Iron precipitation as goethite was chosen for Zhuzhou in order to minimize the amount of iron precipitate and also to enable further processing of precipitate.

## **7. Conclusion**

Outotec, former Outokumpu Technology, has developed a new Atmospheric Direct Leaching Process for zinc concentrates, which eliminates the conventional roasting phase in zinc processing. The process is already used in Boliden's Kokkola zinc plant in Finland and Odda zinc plant in Norway. Now the leading Chinese zinc producer, Zhuzhou smelter group, selected this process for its expansion because it is an environmentally sound way to produce zinc, it includes recycling of process residues, and it represents the latest technology. In addition, a wider selection of zinc concentrates can be used as raw materials in the process, which improves the use of resources.

Outotec's delivery includes the engineering of a zinc plant with new Atmospheric Direct Leaching Process, iron precipitation and solution purification processes, main equipment supplies as well as supervision of installation and commissioning. The expansion will increase the plant capacity by 100 000 tonnes of zinc per year and the plant is estimated to be operational by July 2008.

In order to expand the use of Atmospheric Direct Leaching Process in China, Outokumpu Technology has also signed a Collaboration Agreement with Zhuzhou Smelter Group Co. Ltd.

## **8. Acknowledgement**

The authors thank the management of Outotec Oyj and Zhuzhou Smelter Group Co. Ltd for permission to publish this paper.

## **9. References**

1. Fugleberg S., Järvinen A., "Menetelmä sinkkirikasteen liuottamiseksi atmosfäärisissä olosuhteissa", FI Pat. 100806, 1998
2. Fugleberg S., Järvinen A., "Method for leaching zinc concentrate in atmospheric conditions", US Pat., No. 6,340,450, 2002
3. Takala H., "Leaching of Zinc Concentrates at Outokumpu Kokkola Plant", *Erzmetall* 52, (1999) Nr.1, 37-42.
4. Svens K., Kerstiens B., Runkel M., "Recent experiences with Modern Zinc Processing Technology", *Erzmetall* 56 (2003) Nr.2, 94-103
5. Dyvik F., Borve K., Method for the purification of gases containing mercury and simultaneous recovery of the mercury in metallic form, US Pat. 4,640,751, 1987
6. Lahtinen M., Takala H., Svens K., Järvinen A., Talonen P., Atmospheric zinc concentrate leaching technology of Outokumpu, *Lead & Zinc '05 - Proceedings of the International Symposium on Lead and Zinc Processing*, Kyoto, Japan, October 17-19, 2005
7. Järvinen A., Lahtinen M., Takala H., "Method for Recovery of Zinc by Countercurrent Leaching", WO Pat. Appl. 2004/076698
8. HSC Chemistry® 6.0 User's Guide, Sim Flowsheet Module, ISBN-13: 978-952-9507-12-2, ISBN-10: 952-9507-12-7
9. Takala H., Oinonen Y., Höglund K., Equipment for the leaching of solid matter from sludge, EP Pat. 1225970, 2004

