

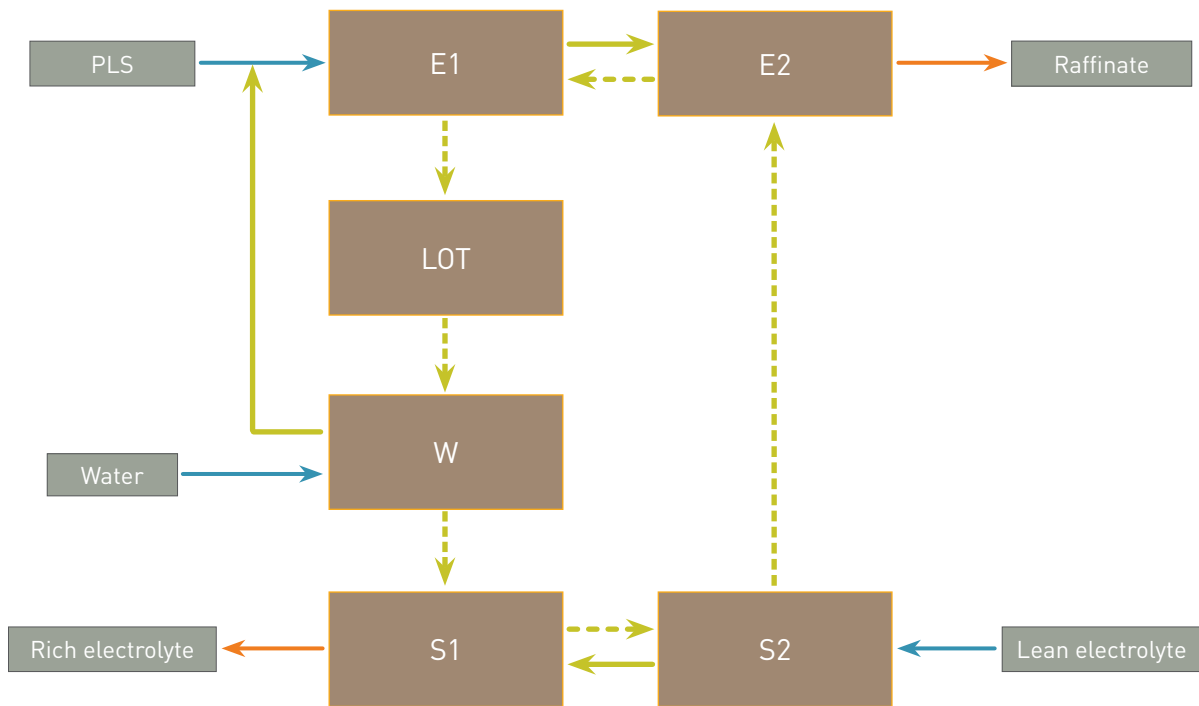

Environmental performance - Solvent extraction

In the solvent extraction phase of the process, incoming pregnant leach solution (PLS) is concentrated and purified, and a pure electrolyte is then used in electrowinning to produce chemically and physically high quality copper, zinc, cobalt or nickel. Our Vertical Smooth Flow (VSF™) mixer-settler technology is the result of the continuous development of mixer-settler technology. The main benefit of the VSF™ technology is that minimal entrainment levels can be achieved without compromising reaction and settling rates. The basic idea behind the VSF™ technology is to have smooth agitation throughout the SX plant to avoid oxidation of organic and development of overly small droplet size in dispersion. This leads to process flexibility, very small reagent losses and crud formation together with improved occupational health and safety level.

Outotec
More out of ore



The flowsheet above shows a typical configuration for a Cu solvent extraction process and gives the raw material and consumables feeds into the process. Typical amounts of waste and emissions generated in the process all calculated on the base of one ton of Cu electrolyte, shown in the table below.

Input

Organic phase

~0.1 kg
/t electrolyte

Water wash

1 % of PLS input

Output/t electrolyte

Organic loss to
raffinate

5 - 15 ppm

Solid waste (crud,
non-hazardous waste)

10 - 100 g

Waste water

None, closed system

Emissions to air
(organic solvent)

~0.01 kg

The information contained herein is made by Outotec for use as illustrative examples only and may not reflect all the realities of actual processes as plant conditions and raw material bases vary. In no event should you rely only on the information contained herein without prior consultations with us.