



Outotec® Thickening technologies



Leading edge technologies for thickening and clarifying

Outotec is a global leader in the design, fabrication and supply of thickening and clarifying solutions for the minerals industry. The revolutionary Outotec® High Rate Thickener has pioneered and redefined thickening and clarifying methods around the world.

Outotec



Outotec® Thickeners and Clarifiers

Innovation is standard

Outotec® Thickeners and Clarifiers operate in minerals processing, alumina, chemical, water treatment, industrial and effluent applications throughout the world. The first Outotec thickener was installed in 1985. The many innovative features of these units, including an ongoing commitment to testwork, R&D, and after sales service, have ensured their rapid acceptance in a wide range of industries.

Outotec's worldwide network manufactures and supports Outotec thickeners, with design offices in Australia, China, Europe, North America, South America and South Africa. This means that no matter where you are, Outotec advanced technology is easily accessible.

Outotec thickeners include a number of innovative features in their design. Special attention is given to the design of feedwells, rake profiles, drive systems and control strategies to meet the challenge of dewatering materials that are often problematic for normal thickeners. Our experience in testwork, design, operation, installation and service of thickeners and clarifiers is renowned throughout the world.

Outotec product range:

- Outotec® High Rate Thickeners
- Outotec® High Compression Thickeners
- Outotec® Paste Thickeners
- Outotec® Conventional Thickeners
- Outotec® Clarifiers
- Outotec® Solids Contact Clarifiers
- Outotec® Lime Saturators

Benefits of Outotec® Thickening solutions



Gold tailings, Australia.

Low capital cost

- Optimized design
- High rate units reduce area by up to 90%
- Precise test work procedures allow accurate sizing

Low operating cost

- Patented "Autodilution" systems minimize flocculant consumption
- Outotec Vane Feedwell™ ensures efficient flocculation
- Simple control system provides stable operation

Guaranteed performance

- Bench-scale and pilot tests provide data for direct scale-up and written guarantees

Design flexibility

- Free standing and on-ground tank options
- Flanged and bolted design for rapid installation

High reliability

- Outotec "low drag" rake design reduces torque loading on drive
- Proven hydraulic drive and rake lift offers three levels of system protection
- Robust control system

Short delivery time

- Full range of CAD designs are quickly tailored to customers' needs
- Global sourcing network

Global service

- Laboratory and on-site testing
- Design offices in North America, Australia, China, South America, Europe and South Africa
- Ongoing process and technical support provided through local offices



Coal paste thickener, Australia.



Lime saturators, Australia.



Copper tailings, Chile.



Sludge clarifier, Australia.



Paste plant, Sweden.



Mineral sands tailings, Australia.



Copper tailings, Chile.

Complete service

Testing

The bench or pilot scale testing can be conducted either on site or in one of our laboratories around the world. Process guarantees are given based on test results.



Selection

Test results and our extensive experience are used to select the appropriate size and type of thickener or clarifier to satisfy the process requirements for each application.

Design

Using FEA and CFD tools, our in-house team ensures the mechanical and process design delivers a high performance, safe and cost-effective solution, specific to each customer. Importantly, Outotec's thickener process expertise delivers an optimized feed system.

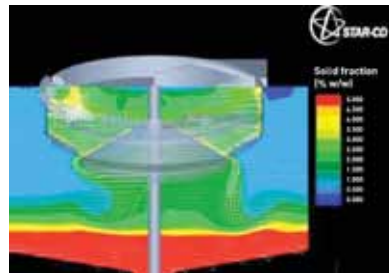

Fabrication

Outotec project engineers monitor fabrication to ensure that the equipment quality meets all aspects of ISO 9001 accreditation.

Installation

Supervision or complete installation supplied. Experienced crews will save time and money. Bolted tank designs, for example, dramatically reduce installation time.



Commissioning

Mechanical and process commissioning performed by Outotec trained engineers.

Process and technical support

Process advice, technical support and service are provided through the Outotec global network.



Bench-scale and pilot plant testing

Testing is required for the selection of correct thickener or clarifier size and configuration for your application. Outotec is renowned for its professional testing service using cylinder settling tests, continuous dynamic bench-scale tests and pilot plant tests.

The method used to accurately determine the size and expected performance of Outotec® High Rate Thickeners and clarifiers is dynamic bench or pilot scale testing, as static settling tests do not adequately simulate the high rate principle.

Bench-scale testing

Continuous bench-scale tests are performed in our 100 mm (4") diameter dynamic thickener or clarifier at site or in our laboratories. A sample of slurry containing 10–25 kg (22–55 lb) of solids is all that is required for a series of tests to determine underflow density and overflow clarity for a range of feed rates and flocculant dosages.

Pilot plant testing

We supply pilot scale thickening and clarifying equipment backed by trained, highly experienced personnel, to meet any process requirement. The size and configuration of equipment is based on material characteristics and performance goals. Outotec has a comprehensive range of pilot plant units for conventional settling, high rate thickening and/or clarifying, high compression and also paste thickening. A feed rate of 1–8m³/h (4.4–35.2 US gpm) of pulp is required for the pilot plant thickener/clarifier.



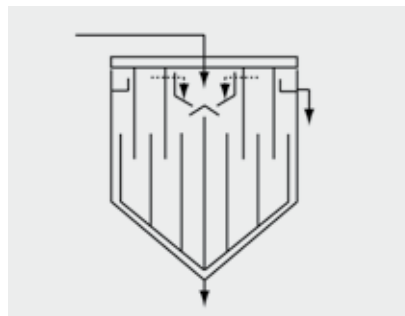
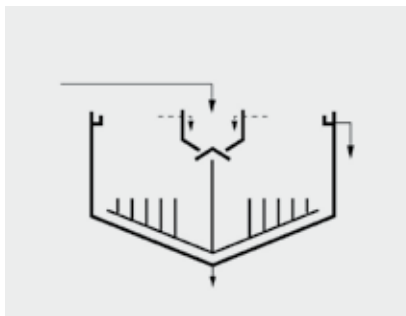
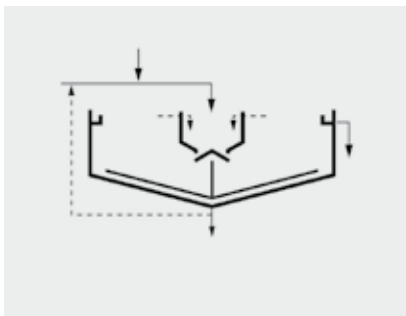

Outotec® High Rate Thickeners and Clarifiers

- Outotec Vane Feedwell™
- Controlled solids inventory
- High throughput per unit area
- Free standing or on-ground tanks
- Short retention time
- Optional underflow recycle
- Clear overflow

Outotec® High Rate Thickeners and Clarifiers suit all applications where flocculants can be used in the process. Also ideally suited to clarifying, with overflow being filtered through a flocculated solids bed. External underflow recycling is sometimes used to improve floc formation and particle capture.

Outotec® High Compression Thickeners

- Outotec Vane Feedwell™
- Controlled solids inventory
- High throughput per unit area
- Free standing or on-ground tanks
- High rake torque capacity
- Extended high compression zone
- Supapickets (static and rotating) for improved water release
- Increased underflow density

Outotec® High Compression Thickeners provide consistently higher underflow density while maximizing solution recovery. They are used for increasing tailings dam capacity, counter-current decantation, increasing filter capacity and improving recovery of process water or chemicals.

Outotec® Paste Thickeners

- Outotec Vane Feedwell™
- Controlled solids inventory
- High throughput per unit area
- Free standing or on-ground tanks
- High rake torque capacity
- Extended high compression zone
- Supapickets (static and rotating) for improved water release
- Maximum underflow density
- Underflow slurry yield stress >200Pa
- Underflow shear thinning systems

Outotec® Paste Thickeners are designed to produce a consistent high yield stress underflow, with process control and mechanical reliability second to none. Primarily used for tailings disposal and pre-leach applications. Paste thickeners can be used for any application where underflow yield stress in excess of 200Pa is required.

74m tailings thickener, Australia



5 x 20 m paste thickeners shipped to New Caledonia



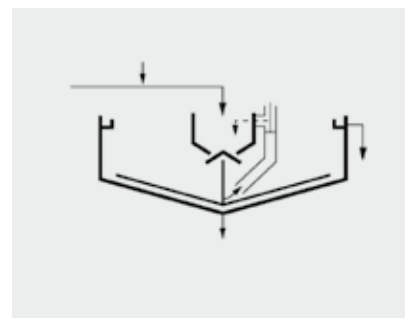
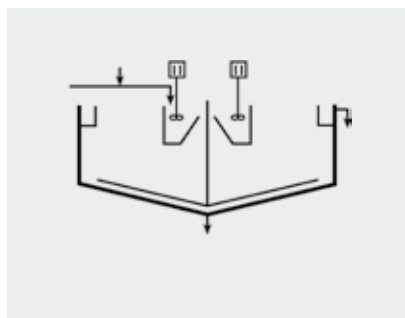
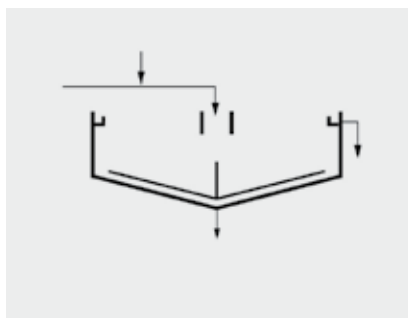

Outotec® Conventional Thickeners and Clarifiers

- Conventional feedwell
- Flocculants not essential
- Intensive to short term process changes
- Drive and rake torque to suit application

Outotec® Conventional Thickeners and Clarifiers are available as “traditional” conventional units or fitted with flocculating feedwell. Hybrid versions are also available, where various design features of our high rate thickeners are used for particular applications. These modifications can result in improved overflow clarity, lower flocculant usage, higher feed rates and enhanced control.

Outotec® Solids Contact and Reactor Clarifiers

- Combines flash mixing, flocculation, clarifying, sludge collection and thickening in one operation
- Minimizes chemical requirements by using the solids contact or seeding principle
- Variable speed impeller and separate rake drive mechanism
- Deep clear water zone
- Internal or external recirculation option
- Dual chemical dosing option

A variable speed impeller can be used to internally recirculate and mix flocculated underflow, raw feed and chemicals to optimize flocculant usage and overflow clarity. Typically used for water or waste-water applications, where chemicals are added to enhance flocculation and sedimentation.

Outotec® Lime Saturators

- Saturated lime solutions
- Over 85% usage of available $Ca(OH)_2$
- Variable speed impeller and separate rake drive mechanism
- Controlled sludge level
- Outotec Vane Feedwell™ for improved solids dispersion
- Internal or external recirculation option

Outotec® Lime Saturators are used to make clarified saturated lime solution for drinking water plants. Milk of lime solution is fed continuously into the reaction zone, where it is mixed with recycled sludge. The sludge is controlled at the required level by varying the sludge withdrawal rate.

Copper tailings, Chile



Lime saturator, Australia

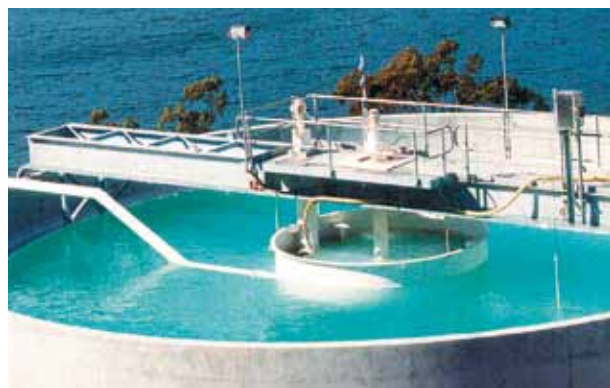

Outotec[®] feed system

Outotec Vane Feedwell™

Feedwells have a significant influence on thickener performance. The Outotec Vane Feedwell™ is a high performance feedwell for the thickening and clarifying industry and is the first major innovation in the thickening industry since the early 1990s. It is now the global standard for Outotec thickeners.

Benefits

- Reduced plant operating cost
- Reduced flocculant consumption
- Increased underflow density
- Higher solids throughput
- Improved water recovery and clarity
- Minimised feed short-circuiting
- Stable operation, less downtime

How does the Outotec Vane Feedwell™ work?

One of its main design features is the interconnected upper and lower zones.

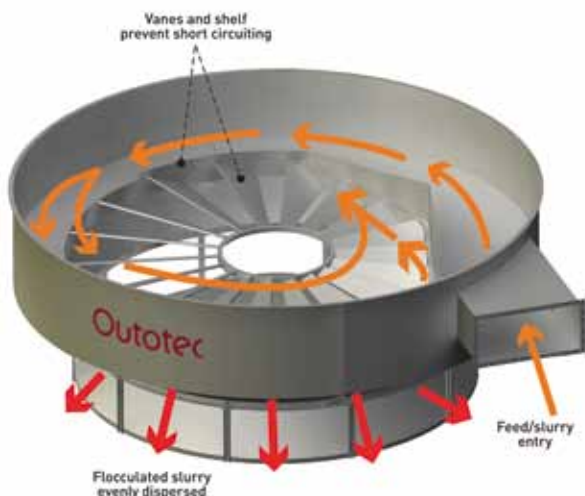

The upper zone, into which feed, dilution water and flocculant are added, provides enhanced mixing and energy dissipation. This maximises flocculant adsorption, eliminates the possibility of coarse/fines segregation and ensures all particles are aggregated together by the flocculant. Efficient operation is maintained in this upper zone over varying feed rates.

The lower zone promotes gentle mixing for continued aggregate growth, with the option for secondary flocculant dosing. This zone also enables aggregates to uniformly discharge under low shear conditions.

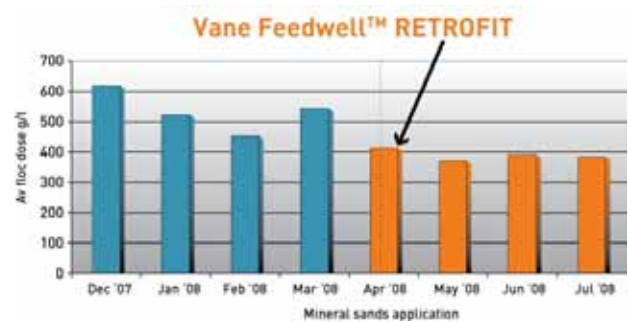

Feed dilution systems - Directional Autodil™

To decrease the feed solids level prior to flocculation, Outotec has developed the patented directional "Autodilution" system which harnesses the natural head difference across the feedwell wall to drive supernatant liquor into the feedwell where slurry dilution, mixing and flocculation take place.

"Autodilution" maintains the density in the feedwell within the optimum range for flocculation, irrespective of feed flow rate or density.

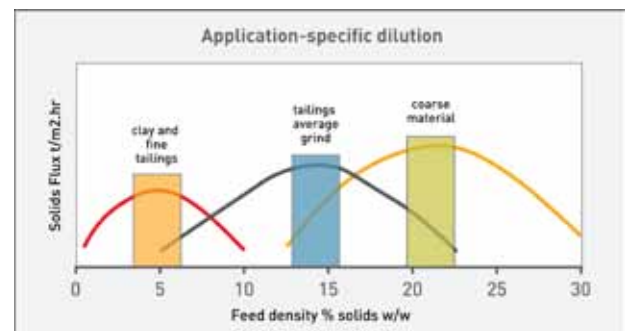

Feed dilution systems - Turbodil™

In some circumstances, the process dictates that an alternative feed dilution scheme be adopted. Such circumstances include:

- A very high degree of feed dilution required by the process
- The requirement for dilution systems to operate over a wide feed volume variation
- Thickener operation with very high feed density and simultaneous requirement for dilution to low feed solids
- Very large feedwell diameters where mixing energy over and above that generated by the incoming feed needs to be provided

Outotec has developed a patented system of forced dilution – Outotec Turbodil™ – using low head axial pump to drive dilution water into the feedwell.

Outotec® High Rate Thickener control

Outotec provide expertise for the control and operation of the thickening process.

Control philosophy

Control systems are built around two fundamental and simple control loops:

- Flocculation is controlled by varying the flocculant pump speed to achieve a consistent flocculant dosage rate per tonne dry solids feed. Bed level can be used as feedback to control the g/tonne set point.
- Solids inventory is controlled by varying the underflow pump speed to achieve a constant "bed mass".

By controlling flocculation and solids inventory, the thickening process is stabilized and a consistent underflow density is achieved.

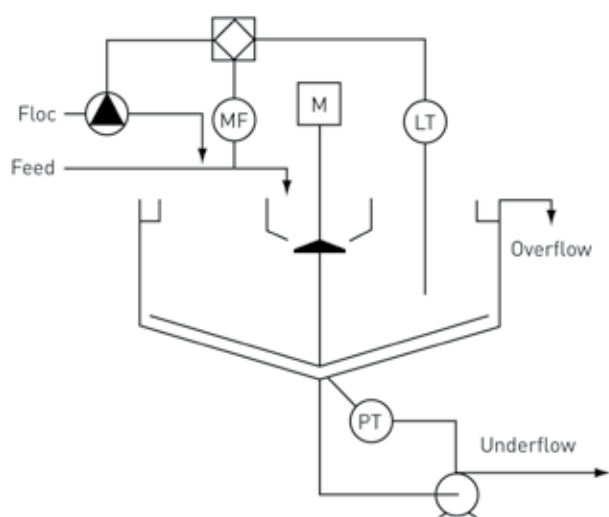

CCD circuits

For a number of thickeners in series, such as a CCD circuit, the basic control philosophy for each unit remains as described.

However, interconnection of control loops occurs down the circuit, leading to increasing disturbances in solids inventory. This is illustrated in typical trending graphs shown. Solids inventory (Bed Mass) is under good control in CCD 1, but the variation in control output from CCD 1 amplifies through the CCD circuit, resulting in larger disturbances in the Bed Mass. By the time it reaches CCD 5, the Bed Mass control is subject to unacceptably large fluctuations adversely affecting operating parameters including Underflow Density and Bed Level.

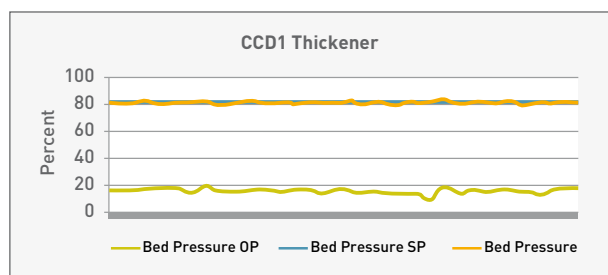

Control maintained

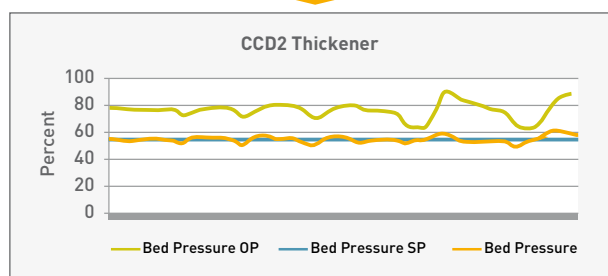

Disturbances increasing in CCD circuit

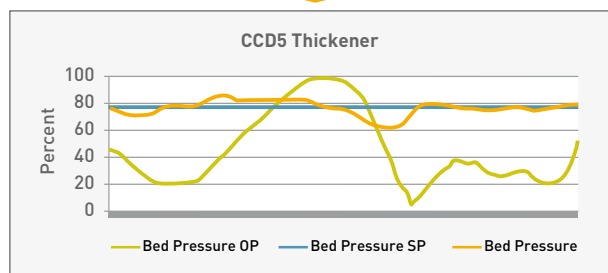

Unacceptably amplified fluctuations, control solution required

Control solution

The disturbances can be controlled by means of a feedforward algorithm equipped with adaptive tuning functionality to allow optimal feedforward gain to be set. This results in stable solids inventory (i.e. bed mass) control down the circuit, and therefore stable bed level and density control is maintained.

Adaptive tuning uses recursive modelling and signal analysis techniques. Depending on plant control system facilities, adaptive tuning is implemented as part of an Outotec thickening control system or it runs on Outotec® ACT expert system platform.

This "higher level" control has been developed for both Flotation and Thickener circuits, and is based on Outotec's extensive experience in plant control methods.



High capacity drive systems

Outotec pioneered the use of planetary gearboxes on full span bridge thickeners. Our drive range encompasses single planetary and multi-pinion gearboxes with hydraulic or electro-mechanical designs for full span and centre column thickeners.

Hydraulic rake drive

A slow-speed hydraulic motor, acting through a high-efficiency planetary gearbox, is used to drive the rakes. The optional rake lifting mechanism comprises a number of hydraulic cylinders operating in parallel, which raise and lower the drive base.

Outotec® Rake Drives are designed to meet each specific application, using off-the-shelf components wherever possible. This system has distinct advantages over traditional multi-stage electromechanical drives:

- Planetary gearbox gives excellent torque and thrust load capabilities
- Accurate torque measurement through hydraulic pressure
- Three levels of drive protection
- Intrinsically safe rake lift
- Reversible

Drive protection and rake lift

The Outotec® Hydraulic Rake Drive offers three levels of drive protection:

- The pressure on the main hydraulic drive is monitored by a pressure transducer which activates the automatic rake raise/lower function
- An independent pressure switch also monitors the hydraulic pressure and activates an alarm and motor trip at a higher pressure set point
- The final level of protection utilizes a pressure relief valve in the hydraulic circuit to guarantee the drive never exceeds the design torque rating
- No possibility of over-torque on start-up or operation

Rake lift – lowered position.

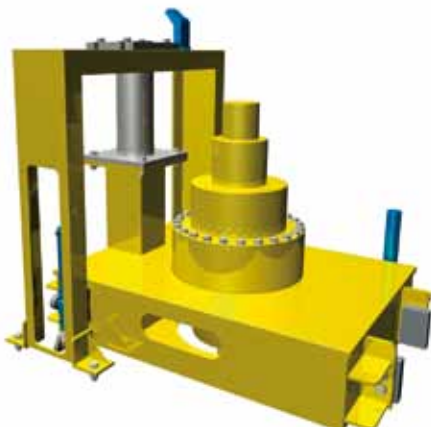

Rake lift – raised position.

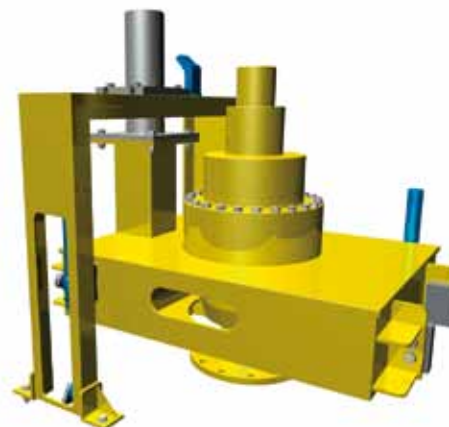



Outotec® Multi-pinion Drives

Outotec® Column Drives (SCD) and Bridge Drives (SBD)

Outotec has developed high capacity multi-pinion drives, using the latest gear manufacturing technology, specifically with maintenance in mind. The ring gear and pinion components are readily available from major manufacturing centers around the world.

Standard drives are available, from 750 kNm to 11500 kNm, and feature:

- Commercial one-piece ring gear and bearing
- Induction hardened metric module gear teeth
- Oil bath lubrication of gear and bearing assembly
- Splined drive from reducer to pinion
- Self-aligning lower pinion bearing
- Hydraulic drive for load balancing between pinions
- Fabricated base housing designed by FEA
- Stress relieving all fabrications prior to commencement of machining
- Optional hydraulic rake lift

Unique system for faster, safer, easier maintenance

Due to Outotec's unique design, the maintenance of Outotec centre column drives is faster, safer and easier than any other on the market. One example of this is the design of our slewing ring and entire drive unit, either of which can be removed for maintenance, without the need to disconnect piping, electrical cabling or the bridge itself.

Other maintenance design features include:

- Single pinion assembly units removed without draining oil
- Stock standard spherical roller bearing for quick sourcing
- Drives unit can continue operation even if a single pinion is removed for maintenance
- Easily accessible rake lift on all centre column drives, located above drive head

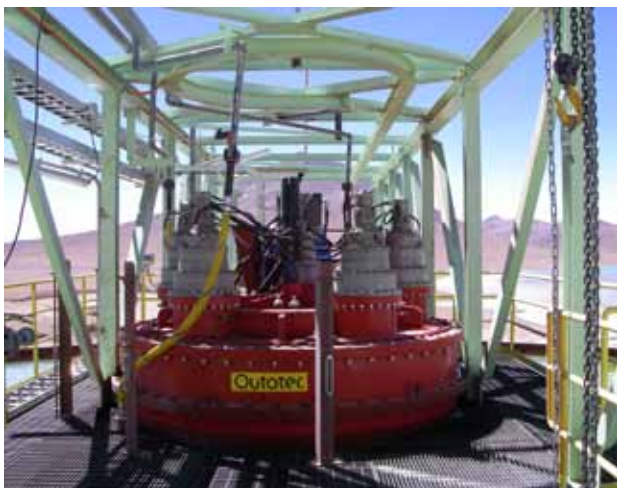

Outotec develops and provides technology solutions for the sustainable use of Earth's natural resources. As the global leader in minerals and metals processing technology, Outotec has developed over decades several breakthrough technologies. The company also offers innovative solutions for the chemical industry, industrial water treatment and the utilization of alternative energy sources. Outotec shares are listed on the NASDAQ OMX Helsinki.

thickening@outotec.com
www.outotec.com

Outotec

Copyright © 2011 Outotec Oyj. All rights reserved.
Outotec and More out of ore! are registered trademarks of Outotec Oyj.